

Adams

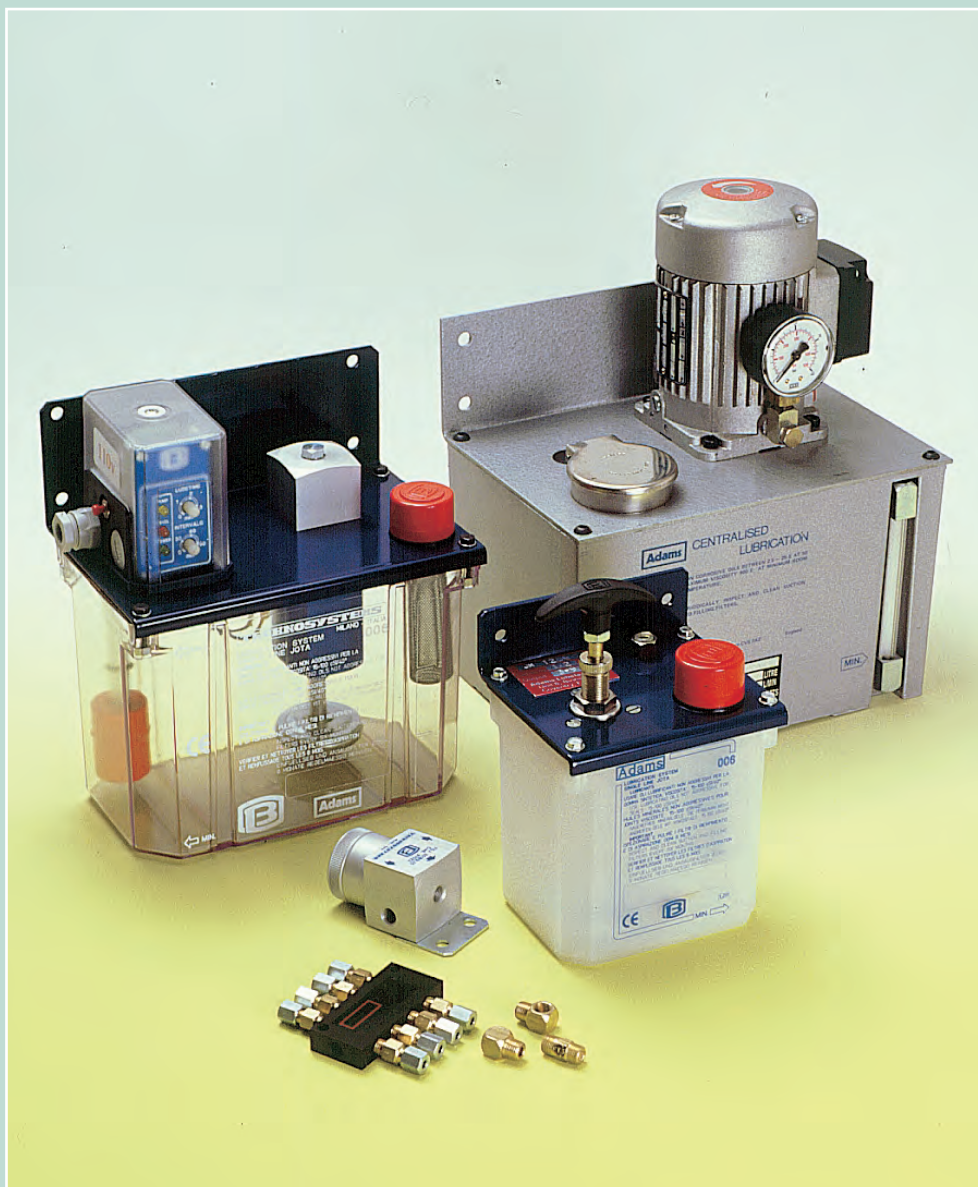

□ Proportional

Proportional lubrication equipment has been developed for use on machinery installations where a comparatively small number of points are to be lubricated using light to medium oils at low pressure. The oil is distributed on a purely proportional basis with the amount delivered to each lubrication point depending on the pump output and the flow rate from the restrictor selected.

There are two types of flow restrictors valves available. METERING, with non return valve for use with cyclic total loss systems, and CONTROL for use on continuous systems.

System Design & Selection of Meter Valves

Whereas the ideal layout for a Proportional System would have equal lengths of tubing at every point, this is rarely possible to achieve and so a selection of metering valves (restrictors) are available to serve the various lubrication point requirements.

The variation of flow restriction of the small bore pipe-work (typically 4mm O/D) can generally be ignored, providing that the viscosity of the oil does not exceed 100 cSt @ 40°C or that the pipe runs are not excessive.

When the layout has been determined, and the position of the pump established, the correct pump must be chosen.

This depends entirely on the amount of oil delivery required per pump operation, allowing 5% extra for system losses due to nylon tube expansion.

Bear in mind that it is the pump output that determines the total volume of oil which is distributed around the system by means of the meter valves or control units - hence the name Proportional.

The selection of the meter valves to suit a particular bearing size is based on the ability of the meter valve flow rate to pass sufficient oil to lubricate the bearing in the 'cycle time' of the pump. A bearing with twice the oil requirement would need a meter valve of the next size up on the flow rate chart.

Always check that the total value for flow rates of meter valves does not exceed the pump output.

Example

System for lubricating a total of 20 bearing points. Of these 10 require 2cc (50 drops) per 8 hour shift. 5 require 4cc (100 drops) and 5 require 8cc (200 drops) per shift. This adds up to 80cc (2000 drops).

Since it is always better to lubricate 'little and often' we will consider a cycle time of 30 minutes using an automatic pump.

The choice of meter valves for the 3 different bearing sizes is in the ratio of 1-2-4, so we may select any three consecutive meter valve numbers, preferably from the middle of the available range. e.g. FS0, FS1 and FS2

To Summarise:-

TYPE OF METER VALVE	QUANTITY	DELIVERY/MIN	TOTAL
FS0	10	0.08cc	0.80cc
FS1	5	0.16cc	0.80cc
FS2	5	0.32cc	1.60cc

Total delivery for all the meter valves is 3.2cc so the pump delivery every 30 mins. would have to be approx. 5cc which requires the pump running time to be set for 1 min. 30 secs. (JNT Type Pump / Timer)

The diagram below shows the layout of a typical system for lubricating 13 delivery points on a machine.

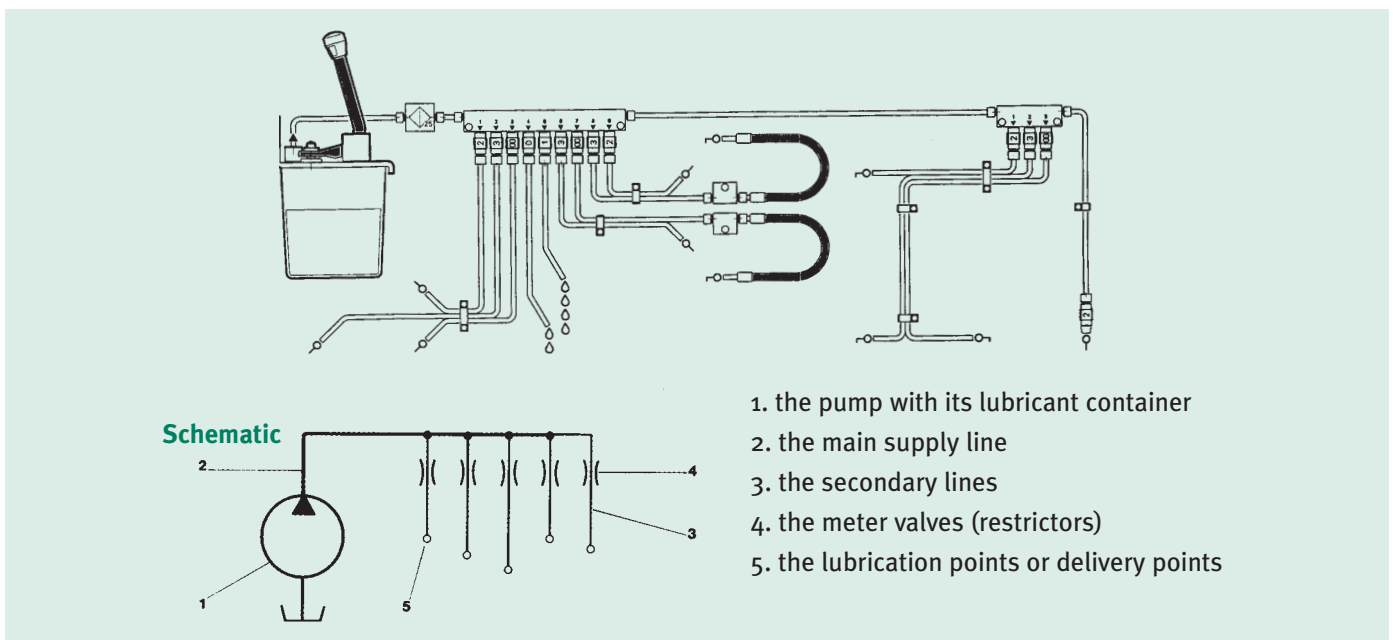

Combined Motorized Pump/Timer with Monitoring

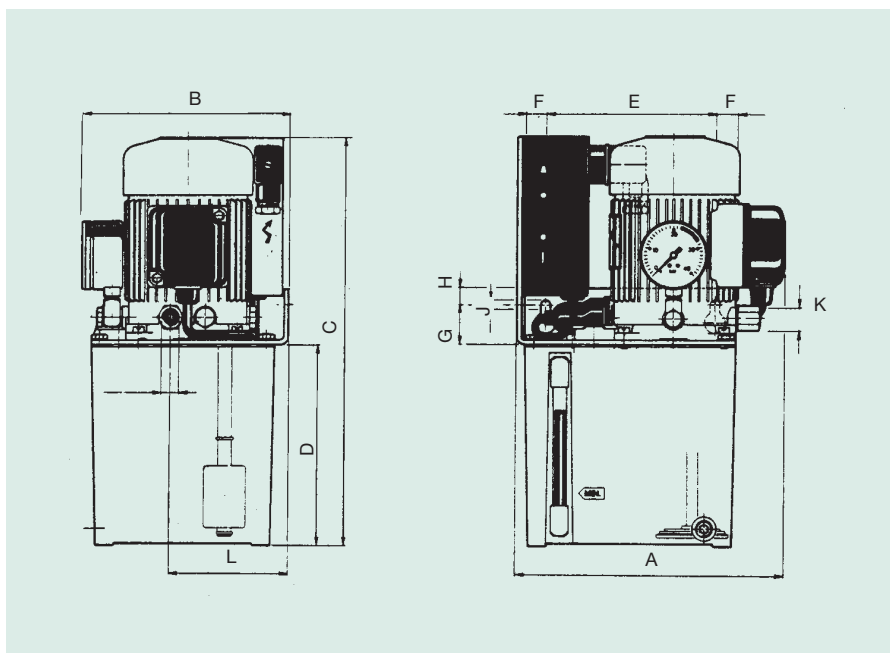

Part No.	Voltage	Res.	Rating	A	B	C	D	E	F	G	H	J	K	L
LV 10290	110/230V	2 Lt Alum.	60 Watt	196	145	296	146	125	15	28	12	7	M12x1	85
LV 10291	50Hz	2.7 Lt Plas.	Intermittent			305	155							

Please state voltage required: 110V or 230V

Note: Outlet connectors are available as following:-

For 4mm Ø tube use Adaptor LV 90020 with Washer LV 91825 Tube Nut LV 90440 and Sleeve LV 90540

For 6mm Ø tube use Adaptor LV 90026 with Washer LV 91825 Tube Nut LV 90460 and Sleeve LV 90560

For 1/4 BSP Female (to screw in Filter LV 10009) use Adaptor LV 90044 with Washer LV 91825

SPECIFICATION

- Motor Rating - 70 Watt Intermittent
- Pump Lubricant Output - 360 cc/min
- Delivery Pressure - 6 bar
- Interval Range - variable 2 min to 8 hours
- Pumping Range - variable 0 to 60 seconds
- Complete with Low Level & Line Pressure Switches, Manual Override Button.

Four L.E.D. Indicators monitoring system condition.

Control Timer will give a Lubrication Cycle on initial Switch 'On' and will repeat at the preset intervals.

Reservoir Oil Levels and System Oil Pressure are continuously monitored and confirmed by Visual Indicators.

'Voltage Free' connections for Remote Alarms and the facility to Stop the machine are also provided.

Anti-vibration mountings for use with above units are shown on Page - 78.

Electromagnetic Pump & Timer

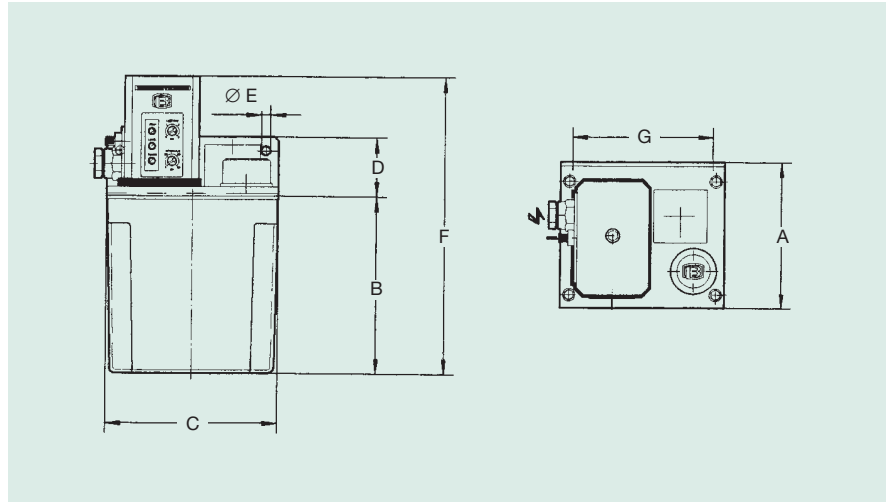

FEATURES

For Single Line Proportional lubrication systems, this compact unit consists of:

PROGRAMME CONTROLLER WITH:-

Pre-Lube function. Manual (Red) override push button.

GREEN - (Flashing) LED showing power ON YELLOW - LED showing pump operating

RED - LED Indicating low level, plus (no voltage contact) for remote signal.

ELECTROMAGNETIC PISTON PUMP:-

Output:- 120cc per minute Pressure:- 3 - 5 bar

Lubricant:- Mineral oil 15 to 100 cSt @ 40° C

Outlet Port - 5/16 x 24 TPI (UNF) 4 mm Ø Tube

PLASTIC RESERVOIR, with Low Level switch. (NO)

SPECIFICATION

TIMER

Interval range - Adjustable 0.3 to 90 Mins Pump run range - Adjustable 0 to 3 Mins

MOTOR

Halfwave Electromagnetic Motor Rating - 70 Watts Protection - Class F

VOLTAGE

24 V - 50/60 HZ

110 V - 50/60 HZ

230 V - 50/60 HZ

LOAD

2.5A

1.7A

0.7A

PLEASE STATE VOLTAGE REQUIRED WHEN ORDERING. Example: LV 65011/110 = 110 volt supply

Part No.		A	B	C	D	E	F	G	Reservoir Capacity
LV 65011	With Timer	110	127	123	40	6.5	210	105	1.2 Lt Translucent
LV 65013		136	150	240	76		235	180	3 Lt Transparent
LV 69661	Without Timer	110	127	123	35		170	105	1.2 Lt Translucent
LV 69667		142	152	155	50		202	125	2.7 Lt Translucent

The above are also available with Normally Closed (NC) low level switch, and without Pre-Lube facility if required.

The use of Anti-vibration mountings are recommended, see page 78 for details.

Motorized Pumps & Reservoir - 3 Phase & Single Phase

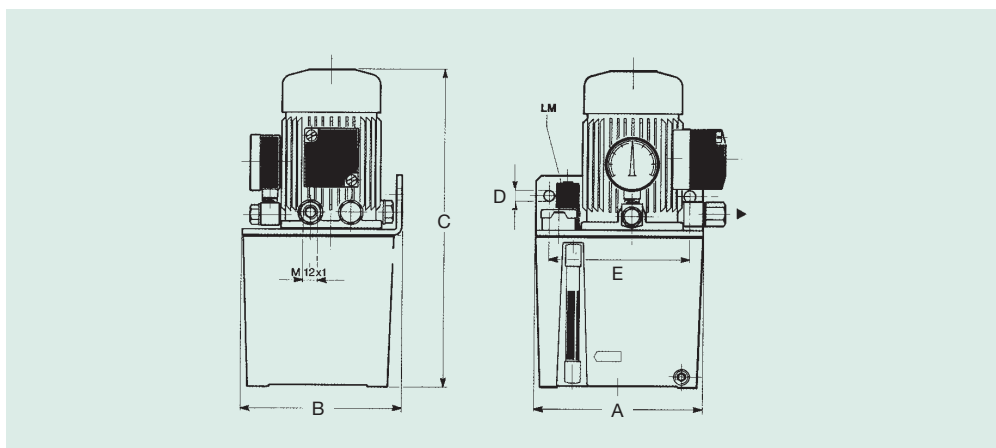

Description

These electrical control units are for supplying Single Line Proportional systems. They are made in two series, one of which uses a three-phase 70 W electric motor with double polarity; and the other is a single-phase motor with the same features. The gear-driven pump has a capacity of 380cc/min. Operating pressure is 4-5 bars which can be regulated by adjusting the regulating valve. Tanks come in a range of sizes (see table at foot of page) and are made of either thermoplastic or die-cast aluminium. The units are equipped with an electric minimum level switch.

Performance

A typical installation is equipped with a motorised unit and a number of single line meter valves. There is no limit to the number of meter valves since either series can deliver up to 380cc./min. It needs a timer control system which provides for a pause time and a working time, adjusted to suit the desired flow from the meter valves being used. The lubrication cycles are repetitive, alternating with rest periods.

Page 20 shows some of the types of timer controls which can be used with these lubrication systems.

Technical Characteristics

MOTOR

	THREE PHASE	SINGLE PHASE
Power Frequency	230/400 V - 50 Hz.	110 - 230 V / 50 - 60 Hz.
Absorbed Capacity	0.37/0.21A	1.8/0.9A
Nominal Power	70 W	70 W.
RPM	2800/3360	2800/3360
Service	continuous	continuous
Protection	IP 54	IP 54
Insulation	class F	class F

PUMP

Capacity 0.36 Lt/min
Max. Pressure 4 bar

SWITCH

Min. level switch LM	single threshold
Contact	NO at min. level
Voltage	250V AC max
Max. Current	3A
Max. Load	120VA
Protection	IP 65
Insulation	class C

3 Phase Motor	Single Phase Motor	Tank Cap. Lt	A	B	C	D	E
LV 63166	LV 63168	2 Alum	155	146	295	6.5	105
LV 63529	LV 63278	2.7 Plastic			298		
LV 63176	LV 67172	5 Alum	248	174	301		

Manual Pumps - Operation of Manual Pump

This system may be used with an average grade of light to medium lubrication oil only.

To operate the pump, pull handle slowly to its fullest extent and release. The pump spring returns the plunger, forcing oil through the distributors and metering valves to the bearings.

The pump handle must be allowed to return normally to the static position, any force will result in damage to the system.

Adams metering valves use capillary elements to control the oil flow. When the pump is operated, pressure is built up in the main lubrication line. The oil passes through the distributors and is passed through the metering valves to the lubrication points. The pressure generated in the average layout is approximately 3.5 bar at the pump outlet. The pressure varies according to the number of metering valves used in the system.

Part No.	Delivery Per Stroke ccm	Reservoir Capacity Lt	A	B	C	D
LV 10224A	7	-	70	40	211	-
LV 63158	6	0.4		78		38
LV 62802	3 To 9	1.2	124	105	168	98
LV 63159				155*		
LV 63170	6 To 18			105		
LV 63160				155*		

* Measurement with Handle/Lever at full extent

In all cases the outlet connection is seated for 4mm \varnothing Tube - Use LV 90443 Tube Nut and LV 90540 sleeve.

Reservoir

Capacity either 0.4 litres or 1.2 litres and made of shock-resistant thermoplastic material.

Pressure

Operating pressure is determined by the thrust of the counter-spring and can be anything between 3.5 and 1.5 bar.

Lubricants

Any lubricant can be used which has a viscosity of between 15 and 100 cSt at 40°C.

LV 10224A

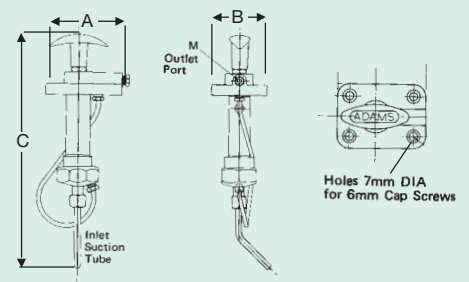

LV 63158 / LV 63170 / LV 62802

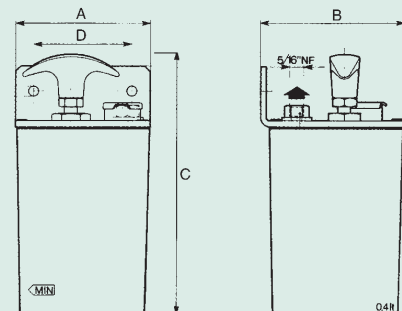

LV 63159 / LV 63160

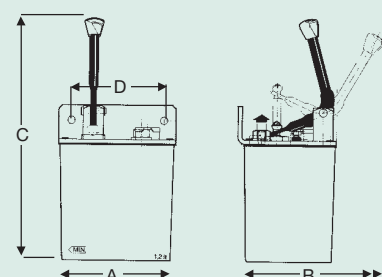

Metering Valves - with Non-Return Valves, for use with Total Loss Cyclic Systems.

Line Type - Screwed into Manifold when feeding lubrication point via 'Tail Pipe'

Part No.	Flow Rate	A	B	C	D	E
LV 10533	BJ000	31	12	9.52 (3/8")	4	5/16 UNF
LV 55000	BJ00					
LV 55001	BJ0					
LV 55002	BJ1					
LV 55003	BJ2					
LV 55004	BJ3					
LV 55005	BJ4					
LV 10534	BJ5					

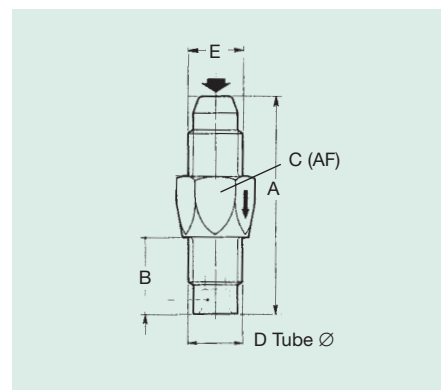

Bearing Type - Screws directly into bearing point (Standard thread 1/8 BSP)

Part No.	Flow Rate	A	B	C	D	E
LV 10535	FS000	26	7.2	9.52 (3/8")	4	1/8 BSP Taper
LV 55018	FS00					
LV 55019	FS0					
LV 55020	FS1					
LV 55021	FS2					
LV 55022	FS3					
LV 54158	FS4					
LV 10536	FS5					

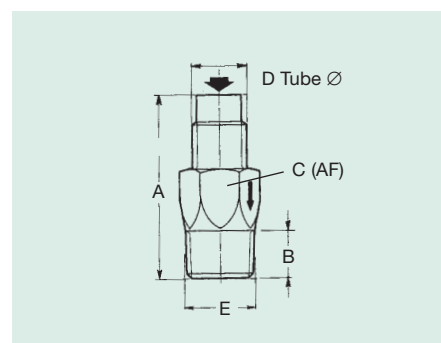

Above Meter Valves also available in NPT Threads.

All above Metering Valves use Tube Nut LV 90743, and Sleeve LV 90840. These fittings are suitable for use with Nylon, Copper and Bundy Tube.

Distribution Manifolds for Meter Valves fitted with Non-Return Valves

i.e. Cyclic Total Loss Systems. All Tube Connections are seated for 4mm Ø Tube, use Tube Nut LV 90443 and Sleeve LV 90540.

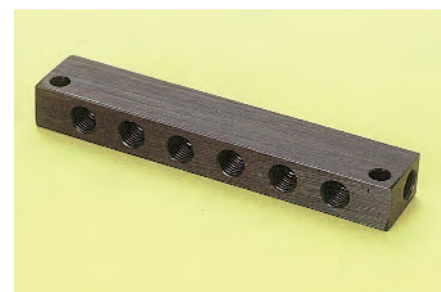

Single Sided

Part No.	No. of Outlets	A	B	C	D	E	F	G	H	J	K
LV 95103	1	30.2	17.5	15.9	15.05	12	20	13.65	7.1	5/16 UNF	4mm Ø tube
LV 95104	2	48.0	33.3								
LV 95106	4	77.7	65.0								
LV 95108	6	109.5	96.8								
LV 95110	8	141.3	128.6								
LV 95111	10	173.0	160.3								

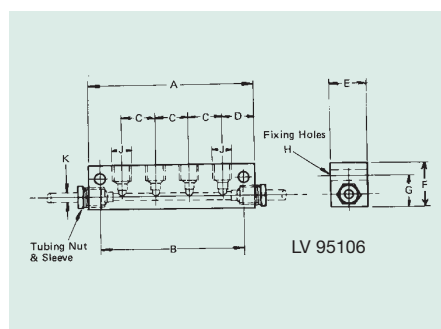

Double Sided

Part No.	No. of Outlets	A	B	C	D	E	F	G	H	J	K
LV 95205	4	46	33.3	15.9	15.05	12	30	23.65	7.1	5/16 UNF	4mm Ø tube
LV 95206	6	61.9	49.2								
LV 95207	8	77.7	65								
LV 95208	10	93.7	81								
LV 95209	12	109.5	96.8								

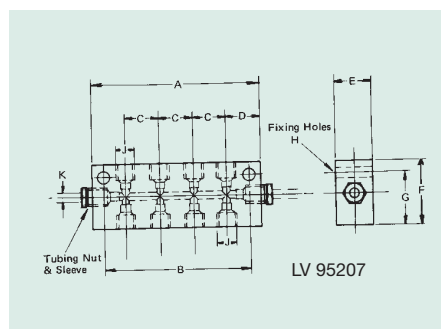

4mm tubing nuts and sleeves not supplied Material - Aluminium

Metering Valves - With non-return valve

Tee Type - use with Junction Fittings shown below

Part No.	Flow Rate	A	B	C	D
LV 55023	FT 00	21.43	7.2	7.2	1/8 BSP Taper
LV 55024	FT 0				
LV 55025	FT 1				
LV 55026	FT 2				
LV 55027	FT 3				
LV 54159	FT 4				

Above Meter Valves also Available in NPT Threads

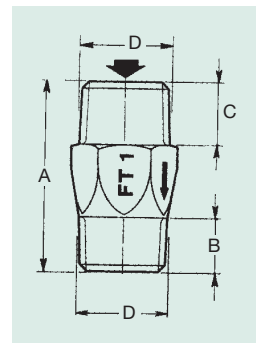

Junction Headers 3 way and 4 way

All tube connections are seated for 4 mm Ø tube,
use Tube Nut LV 90443 and Sleeve LV 90540

Part No.	Ways	A	B	C	D	E
LV 91528	3	17.46	11.9	12.7	6.35	1/8 BSP
LV 91927	3					
LV 91558	3					
LV 91529	4					
LV 91559	4					

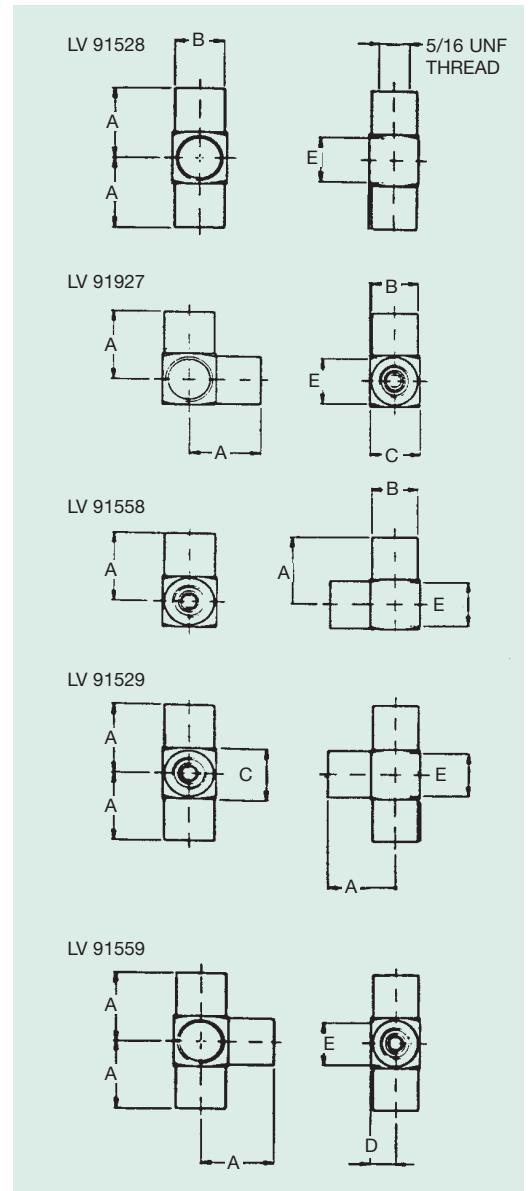

Control Units -

Without non-return valve, for flow control on Continuous Systems

Line Type - screwed into manifold when feeding lubrication point via 'Tail Pipe'

Part No.	Flow Rate	A	B	C	D	E
LV 10121	L1	33	9.5	10	4	M8x1
LV 10122	L2					
LV 10123	L3					
LV 10124	L4					
LV 10125	L5					
LV 10126	L6					
LV 10127	L7					
LV 10128	L8					
LV 10129	L9					

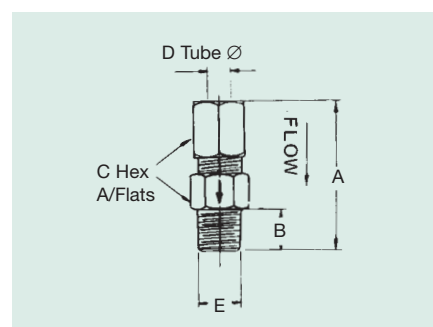
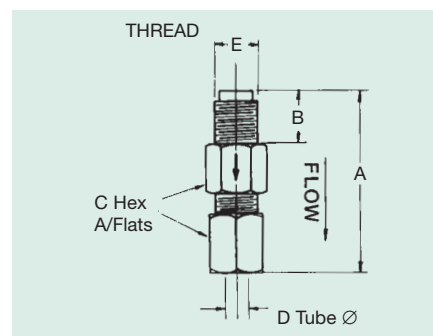

Bearing Type - screws directly into bearing point. (standard thread 1/8 BSP)

Part No.	Flow Rate	A	B	C	D	E
LV 10131	B1	30.2	8	10	4	1/8 BSP Taper
LV 10132	B2					
LV 10133	B3					
LV 10134	B4					
LV 10135	B5					
LV 10136	B6					
LV 10137	B7					
LV 10138	B8					
LV 10139	B9					

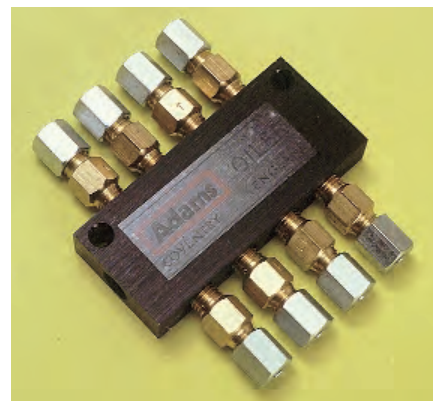

Distribution Manifolds

For Control Units NOT fitted with non-return valves i.e. Continuous Proportional Systems. All Tube Connections are seated for 4mm Ø Tube, use Tube Nut 36-0500-02 and Sleeve 36-0501-02.

Single Sided

Part No.	No. of Outlets	A	B	C	D	E	F	G	H	J	K
LV 10080	2	42.9	33.3	14.3	14.3	12.7	19	14.3	5.16	M8x1	4mm Ø tube
LV 10081	4	71	61.9								
LV 10082	6	100	90.5								
LV 10083	8	129	119								

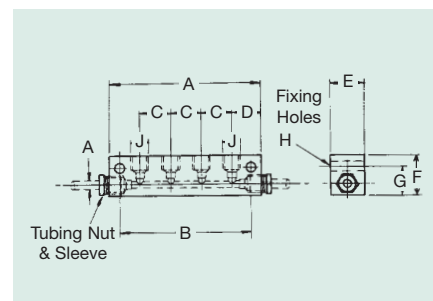

Double Sided

Part No.	No. of Outlets	A	B	C	D	E	F	G	H	J	K
LV 10090	4	42.9	33.3	14.3	14.3	12.7	28.5	23.8	5.16	M8x1	4mm Ø tube
LV 10091	6	57.2	47.6								
LV 10092	8	71	61.9								

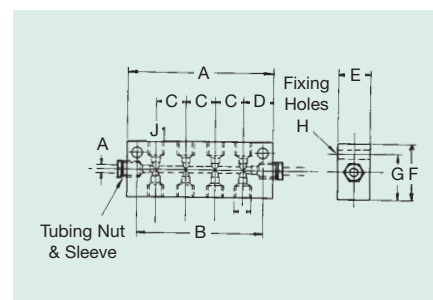

4mm tubing nuts and sleeves not supplied

Material - Aluminium

Accessories

Angle Adaptors

Part No.	Angle	A	B	C	D Taper	E
LV 10148	90°	12.7	8	12	1/8 BSP	1/8 BSP
LV 10149	45°	14.2	8.6	14.2		

Material - brass

Finish - natural

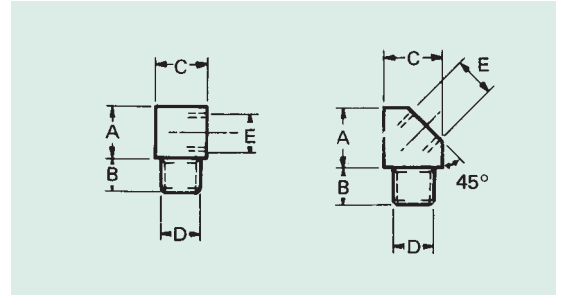

Pressure Gauge

Part No.	Pressure Range	Diameter	Thread
LV 10406	0-10 bar	50	1/8 BSP



Pressure Switch - with Din Plug to IP 65

Part No.	Adjustment Range Bar	A	B	Thread
LV 10550	0.15-10	73	27A/F	1/4 BSP

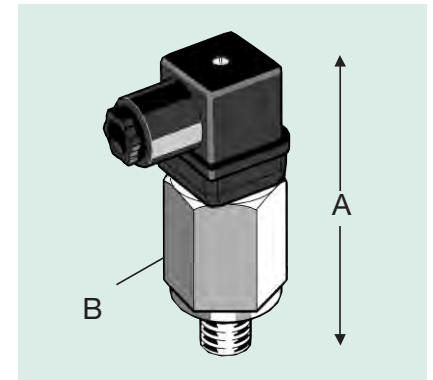

Flow Filters - Outlet filters with sintered bronze filter element enclosed in an anodised aluminium casing. Entry possible from either side depending on design instructions. Can be cleaned by unscrewing the cap T, taking out the filter element SJ, then washing and blow-drying both items.

Part No.	Filtration degree	Pressure max. bars	Flow litres/min.
LV 97522	25 micron	12	1.2

A	B	C	D	F	H	J
40	42	10	1/8 BSP	7	80	25

